

AUKI

Hee Welling | 2015



AUKI

Hee Welling | 2015

There are moments during the day that go beyond a right angle and that seek the sinuous embracing line that supports and relaxes the body. These are moments for the AUKI armchair. Just like a shell, its curved shape gently opens up to create a subtle armrest. The headrest and stool complete its sheer comfort and transform the chair into an elegant chaise-longue. A wide choice of base supports, for the two different complementary small tables, square and round, enhances this perfectly versatile armchair.



AUKI

Hee Welling | 2015

| S113 lounge chair star-shaped swivel base

Lounge chair with internal metal frame upholstered with fire-retardant moulded polyurethane foam and covered with fabric, soft leather or eco-leather. Star swivel base in sandblasted aluminium or powder coated, also available with return-mechanism of the seat. Glides in polythene.

TEST 1 IM - Remix

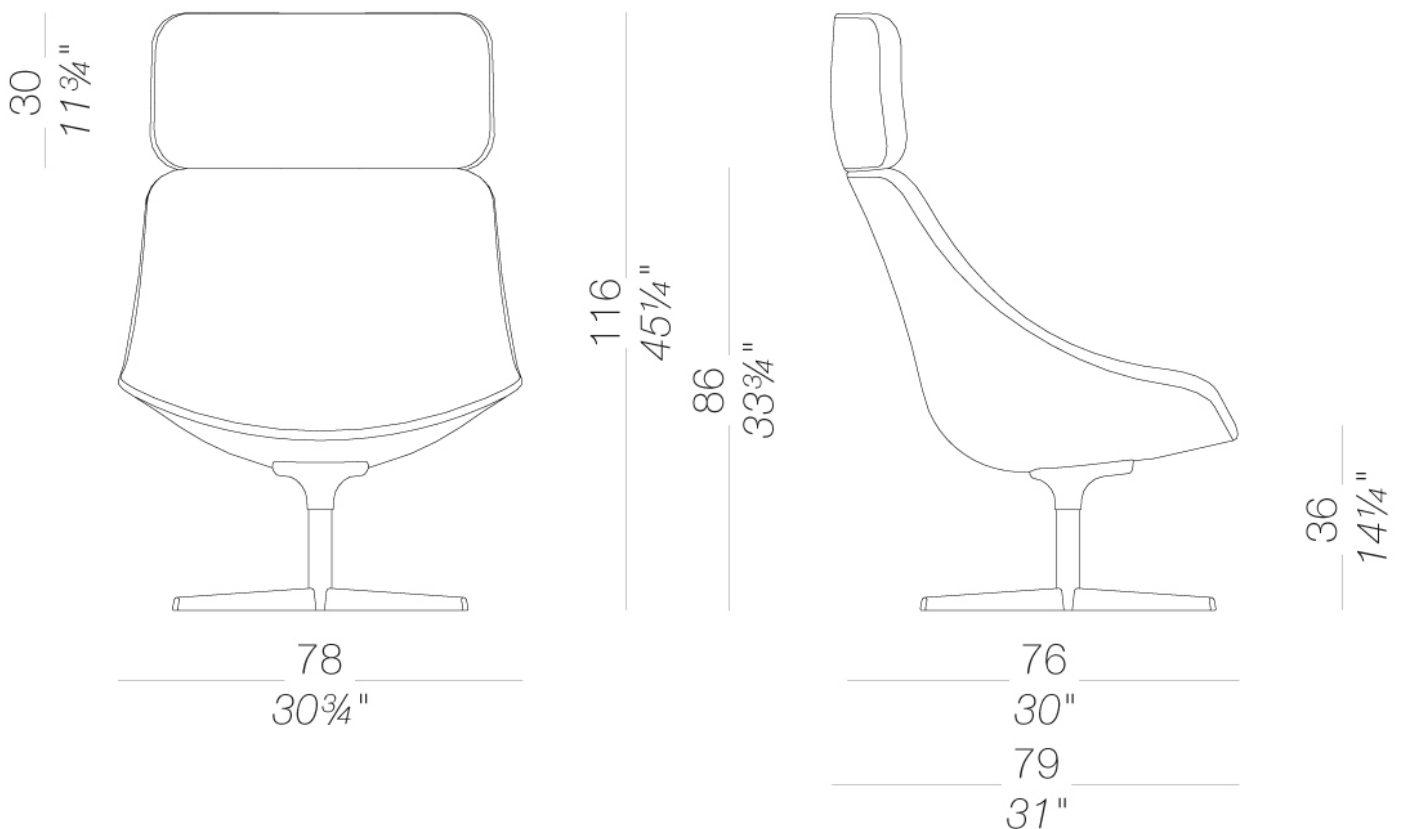

AUKI

Hee Welling | 2015

| S115 lounge chair upholstered wood legs

Lounge chair with internal metal frame upholstered with fire-retardant moulded polyurethane foam and covered with fabric, soft leather or eco-leather. Four legs in solid wood in several finishes. Glides in felt.

TEST 1 IM - Remix

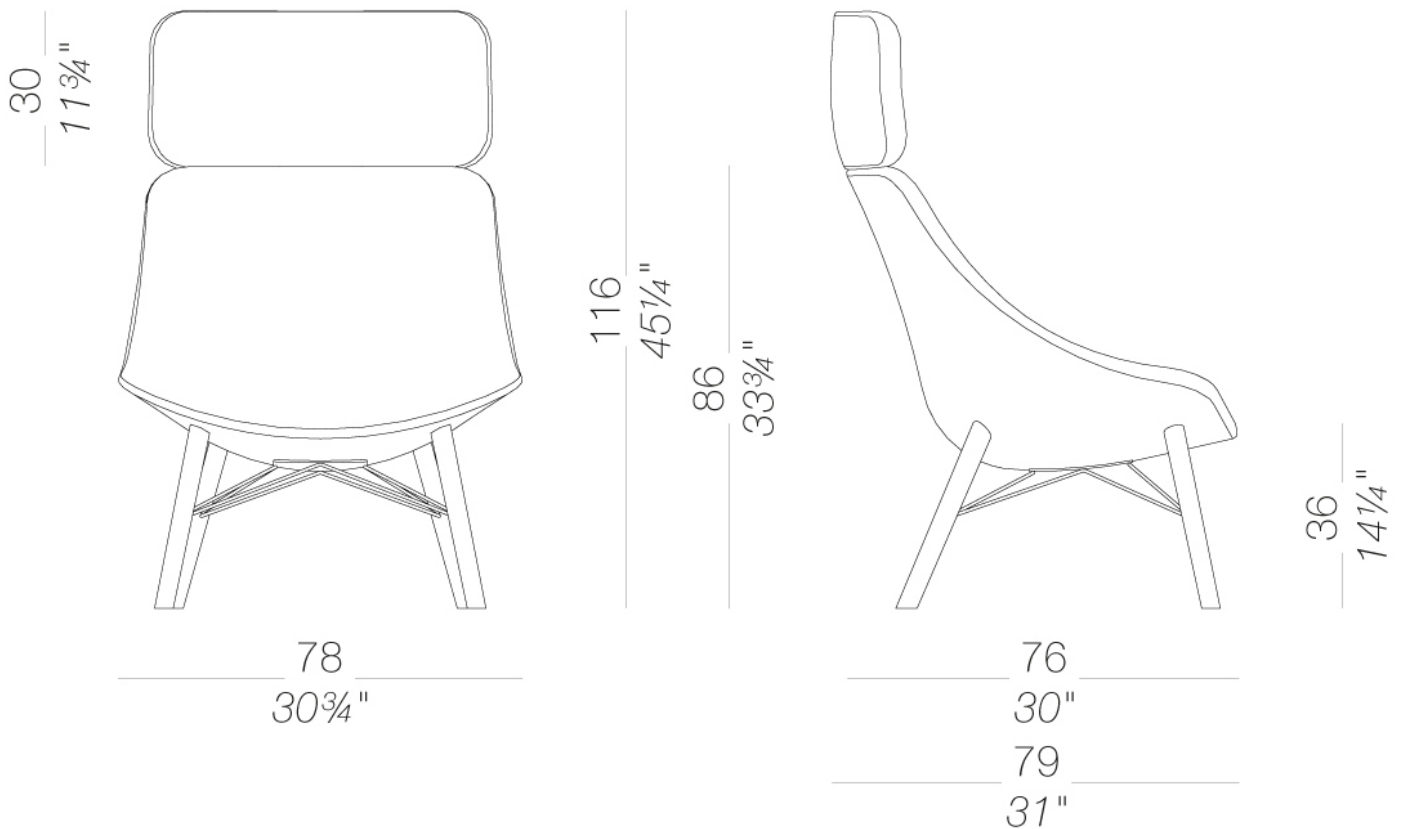

AUKI

Hee Welling | 2015

| S112 lounge chair upholstered with metal legs

Lounge chair with internal metal frame upholstered with fire-retardant moulded polyurethane foam and covered with fabric, soft leather or eco-leather. Four legged base in mat chromed metal or powder coated. Glides in nylon with felt.

TEST 1 IM - Remix

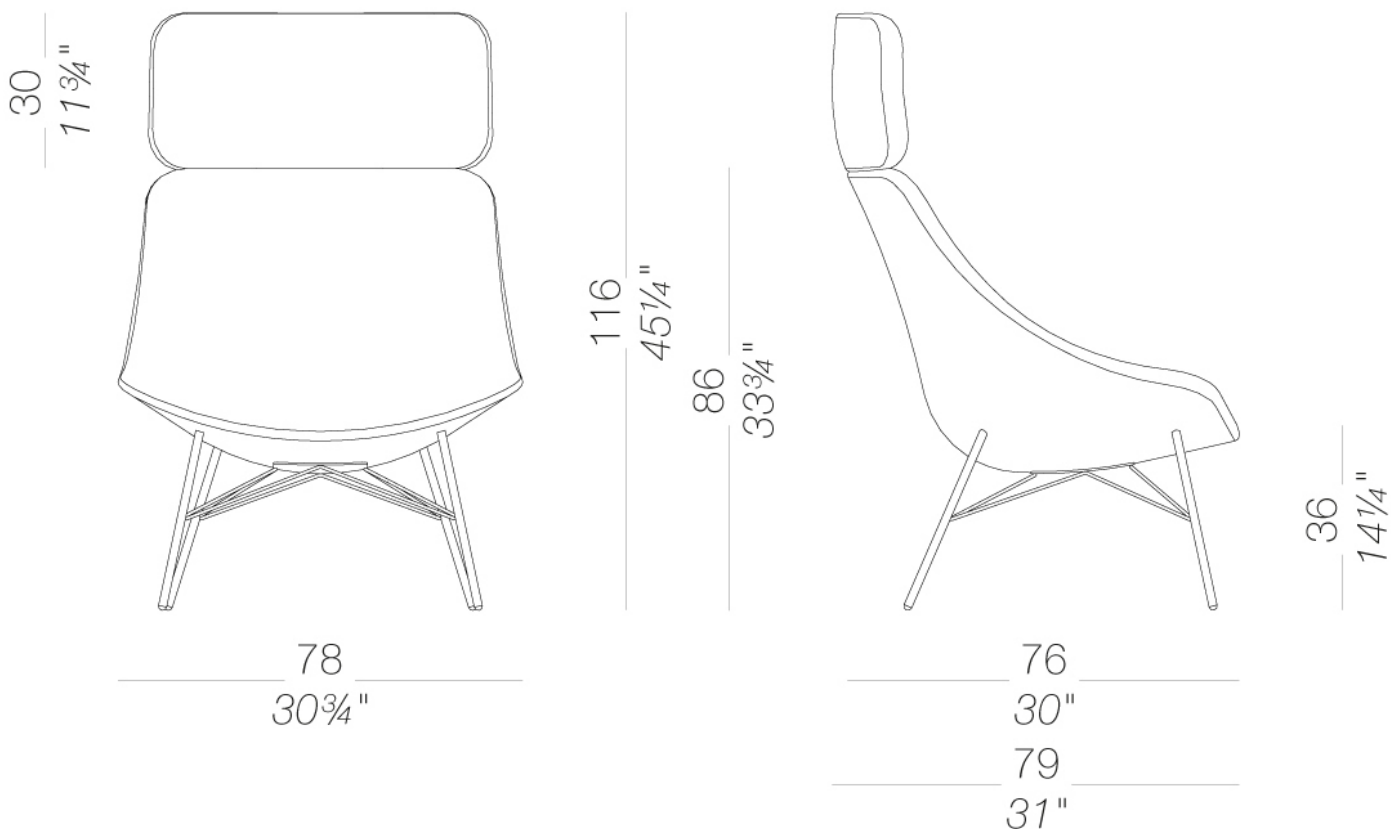

AUKI

Hee Welling | 2015

| S117 lounge chair with round swivel base

Lounge chair with internal metal frame upholstered with fire-retardant moulded polyurethane foam and covered with fabric, soft leather or eco-leather. Round metal swivel base covered by a stainless steel sheet or powder coated, also available with return-mechanism of the seat. Felt under the base.

TEST 1 IM - Remix

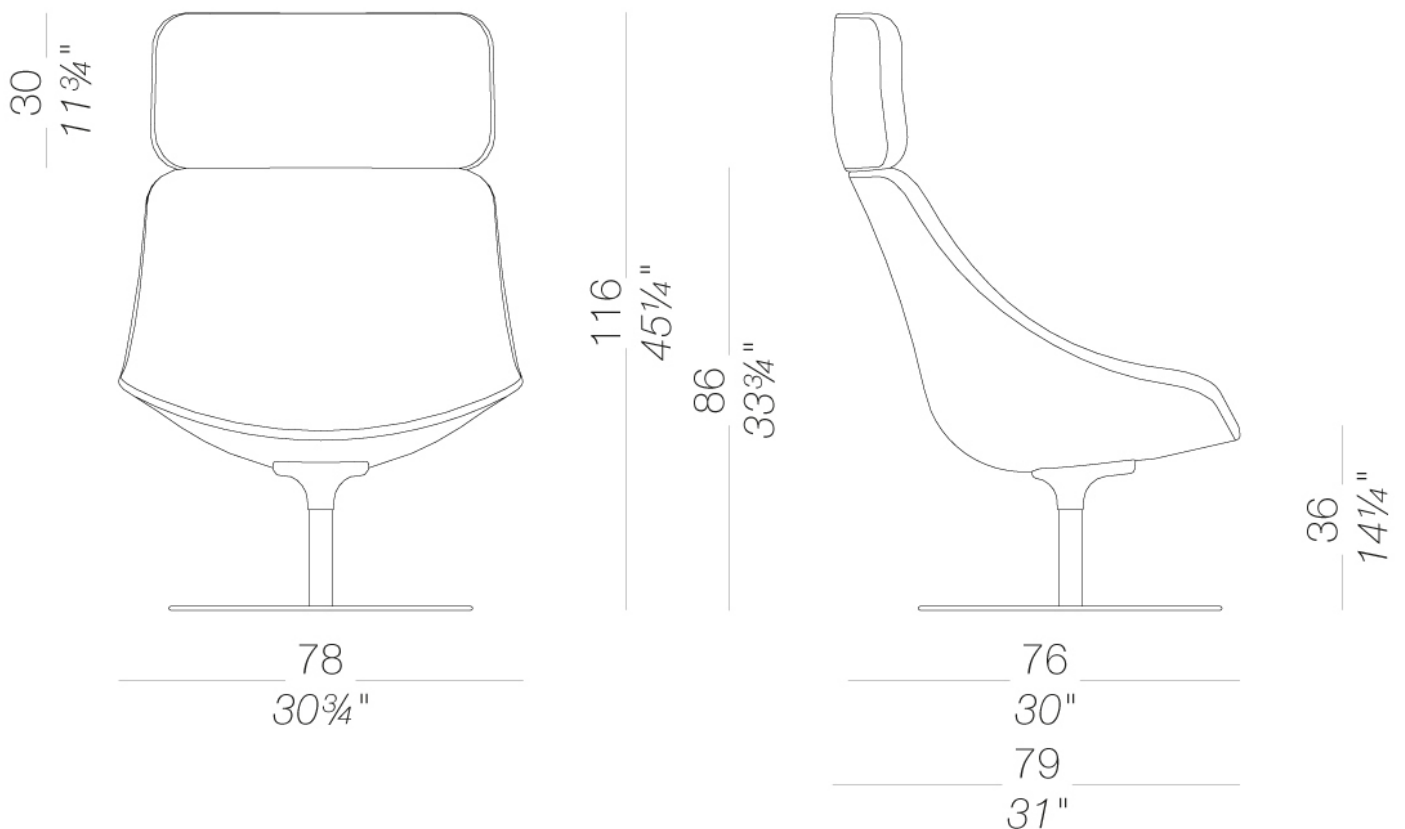

AUKI

Hee Welling | 2015

| S114 footrest upholstered with star-shaped metal base

Footstool with internal metal frame, upholstered with fire-retardant moulded polyurethane foam and covered with fabric, soft leather or eco-leather. Star base in sandblasted aluminium or powder coated. Glides in polythene.

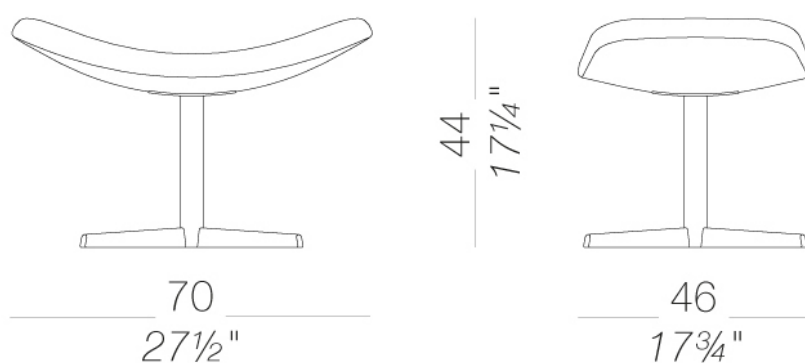

AUKI

Hee Welling | 2015

| S116 footrest upholstered with wood legs

Footstool with internal metal frame, upholstered with fire-retardant moulded polyurethane foam and covered with fabric, soft leather or eco-leather. Four legs in solid wood in several finishes. Glides in felt.

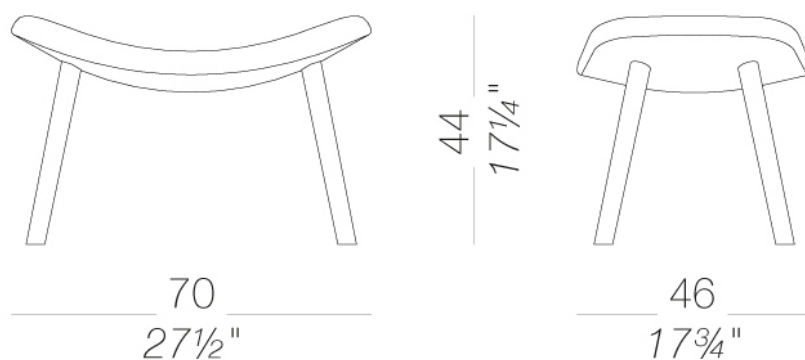

AUKI

Hee Welling | 2015

| P19 Round small table with ash legs Ø80 H.40

Coffee table with solid wooden legs in natural ash or black stained. Top in HPL Fenix® 10 mm.

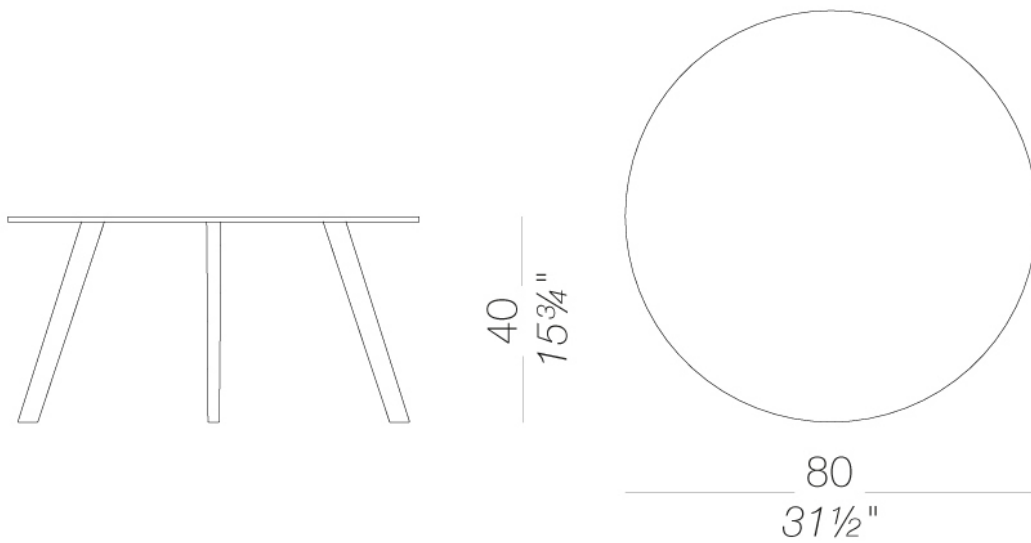

AUKI

Hee Welling | 2015

| H40 With star-shaped base Ø60 60x60 | Ø80 80x80

Coffee table with star base in aluminium, column and fixing plate in powder coated steel. Glides in polythene. Table tops in plywood of birch wood veneered in several finishes or in laminate with visible plywood edge, or in HPL laminate 10 mm.

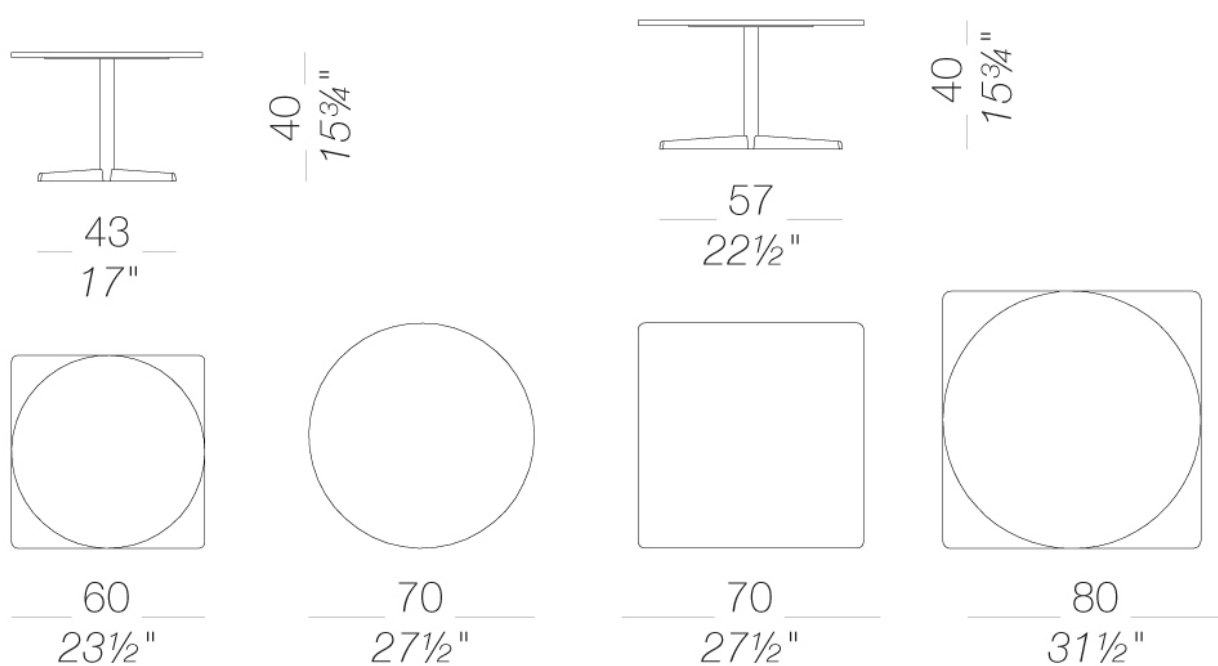

AUKI

Hee Welling | 2015

| H72 star-shaped base Ø60 60x60 | Ø80 80x80

Table with 4 star die cast aluminium base and metal column powder coated. Feet in polythene. Tops in plywood of birch, wood veneered or laminates in several finishes with visible edge. Also available in full laminate 10 mm. in several finishes.

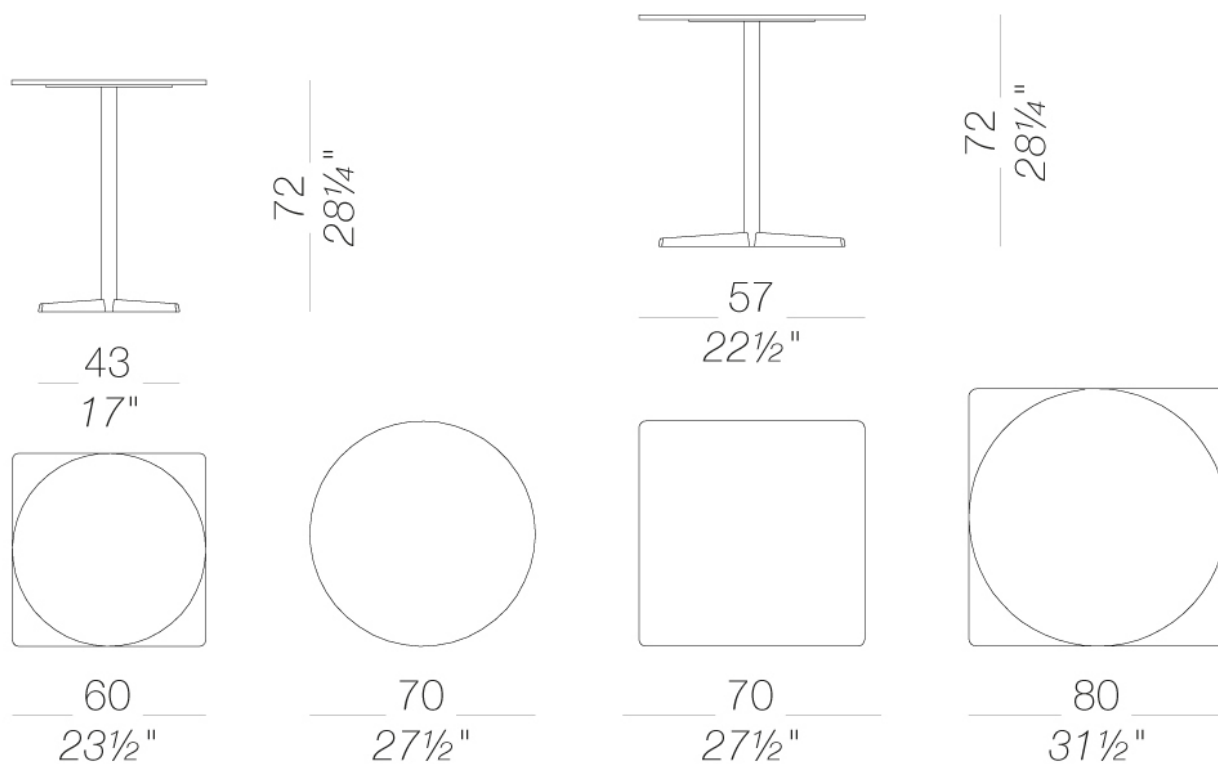

AUKI

Hee Welling | 2015

frame



powder coating
black
1 Colors



wood
natural ash
1 Colors

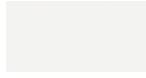

powder coating
white
1 Colors

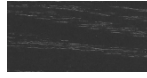

wood
black open pore
1 Colors



metal
mat chromed
1 Colors



metal
stainless steel
1 Colors

upholstery

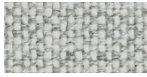

fabric
Hallingdal 65 -
Grade C
58 Colors



fabric
Canvas 2 - Grade C
45 Colors



fabric
Steelcut Trio 3 -
Grade D
54 Colors



fabric
Remix 3 - Grade C
72 Colors

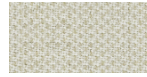

fabric
Clara 2 - Grade C
24 Colors



fabric
Fiord 2 - Grade C
39 Colors



fabric
Divina MD - Grade D
27 Colors



fabric
Divina Melange 3 -
Grade D
38 Colors



fabric
Tonica 2 - Grade C
39 Colors



fabric
Medley - Grade A
37 Colors

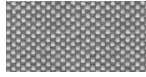

fabric
Maya - Grade A
43 Colors

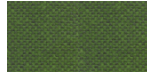

fabric
Jet - Grade A
66 Colors



fabric
Lapalma Smart -
Grade C
18 Colors

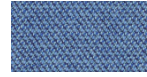

fabric
Capture - Grade B
43 Colors



fabric
Crisp - Grade B
40 Colors



fabric
Nattè - Grade B
30 Colors



fabric
Iris - Grade B
24 Colors



fabric
Steelcut 3 - Grade D
40 Colors

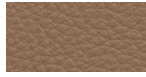

soft-leather
Soft-leather
17 Colors



ecoleather
GRIMM FR - Grade
A
32 Colors



ecoleather
Valencia - Grade B
66 Colors



fabric
Grain - Grade. B
50 Colors



fabric
Re-wool - Grade C
21 Colors

top



HPL 10 mm
black HPL fenix
1 Colors



laminate
406 abet 9/10
1 Colors



HPL 10 mm
HPL H406
1 Colors



HPL 10 mm
white HPL fenix
1 Colors

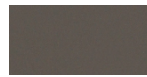

HPL 10 mm
HPL fenix grigio
Londra
1 Colors



HPL 10 mm
HPL fenix rosso
Jaipur
1 Colors



wood
blanch oak
1 Colors

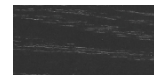

wood
black open pore
1 Colors



wood
oak dark w/ lacquer
1 Colors



lacquered
white lacquered
1 Colors

consult the portfolio for the range of colors, fabrics, eco-leather, soft-leather.

use and maintenance instructions

Clean all parts in wood, leather, fabric and metal with a damp cloth or a diluted neutral cleaner. Do not use cleaners with alcohol, bleach, solvent or abrasive products. Any liquid spilt on the product must be wiped up immediately. When lifting or moving the product, hold it on the structure and not under the seat. The product should not be subjected to unbalanced weights, as it is designed for a proper rest on the foothold (on four legs or on the base). Our company relieves from any responsibility in case of damage caused to fragile floors. Avoid any improper use of the product: do not step on the product, on the footrest or on the armrests. Avoid any movements that could compromise the proper functionality of the product or the safety of the users. Wood and leather, being natural materials, could be easily damaged. Small impurities or imperfections are within quality standard range. Do not expose the product to weather conditions or atmospheric agents, nor to heat sources over 40°C. Also products for outdoor use could be afflicted by atmospheric agents. The product could undergo possible exterior changes due to particular exposure to heat, humidity and saltiness. An appropriate and frequent maintenance and cleaning of the product enhances its durability. The product could change colour and shade, if exposed to direct sunlight. Maintenance has to be carried out by experienced staff. Dispose of the package only after assembling the product, in order to avoid the loss of ironmongery and components. Once the product has been dismantled, the product itself or its components must be given to the public garbage disposal system, according to the legislation in force.