

PLUS

Francesco Rota | 2017

They look for and attract each other. This combination of shapes and colours gives rise to PLUS sofas, a system of modular elements that enhance the character of all community spaces. The profile is soft and the seat is generously wide enough to accommodate the body lying down. A host of solutions can be found, thanks to an extremely simple linking system that re-arranges shapes and redefines the profile. A small but important world for gathering at home, in the office or in any space. And when you want a moment to yourself, the SCREEN panel, which can be used as a backrest, creates a very discreet area.

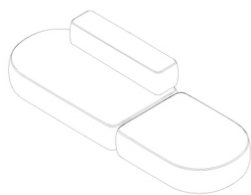



Classic curved

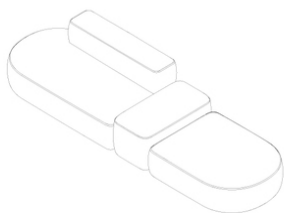

Classic curved – medium

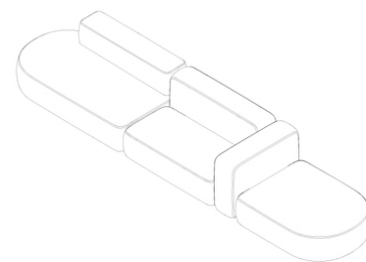

Classic curved – big

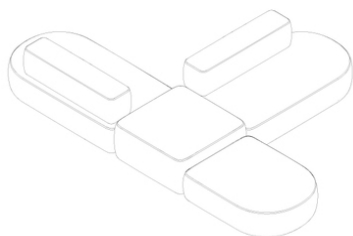

T_shape

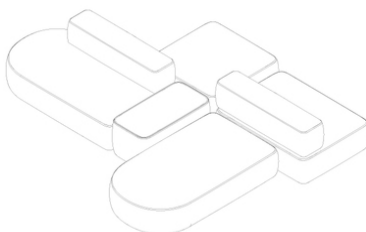

Island

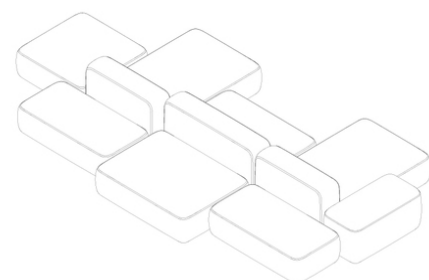

Island – big

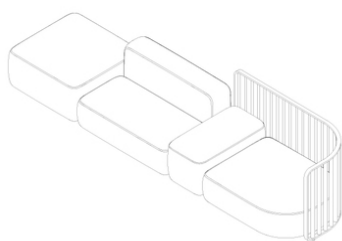

Classic curved – big + screen

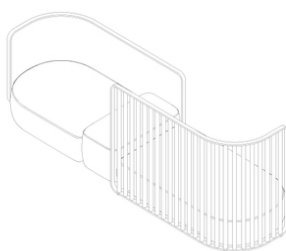

Vis-à-vis

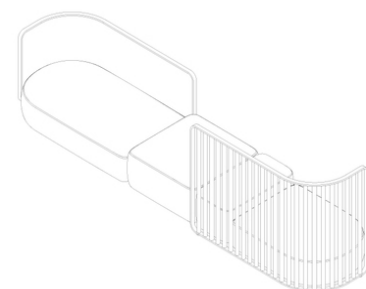

Vis-à-vis – big

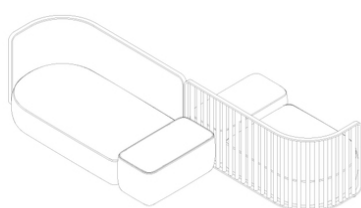

S_shape

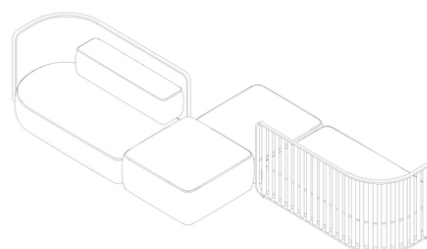

S_shape – medium

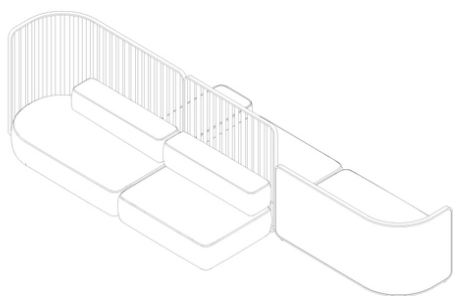

S_shape — big

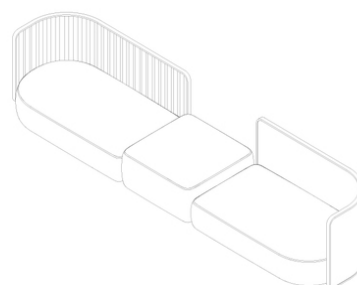

Side by side

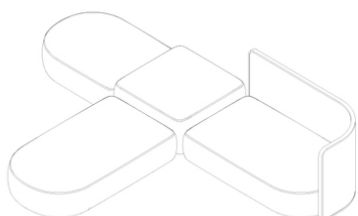

T_shape + screen

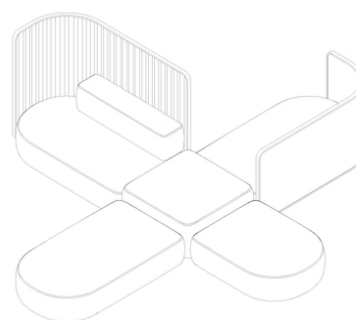

X_shape + screen

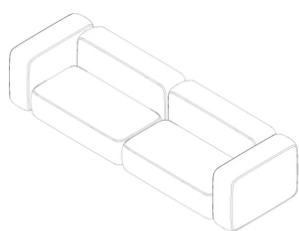

Classic

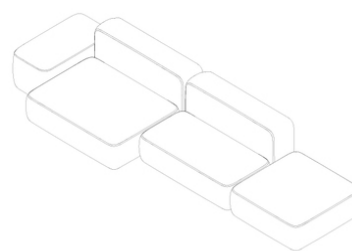

Classic — medium

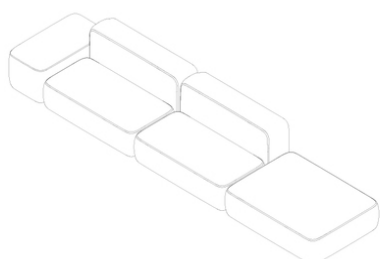

Classic — big

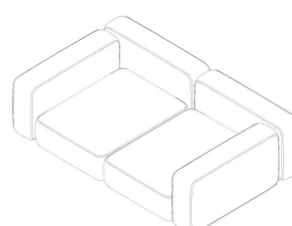

Classic — deep

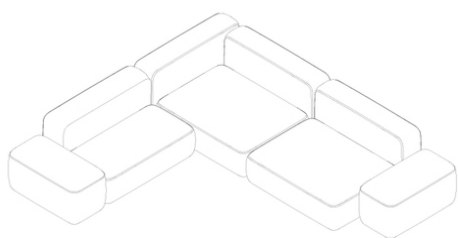

L_shape

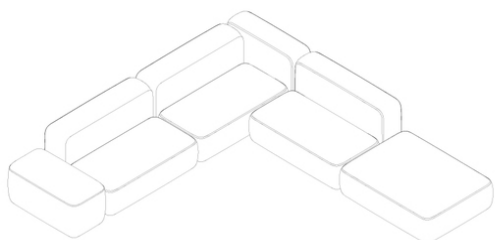

L_shape - 2

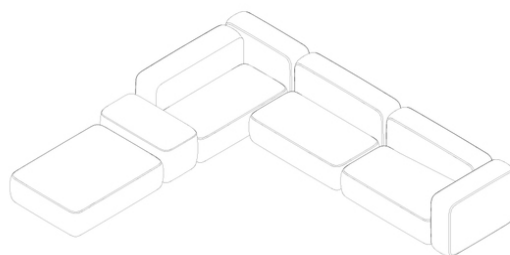

L_shape - 3

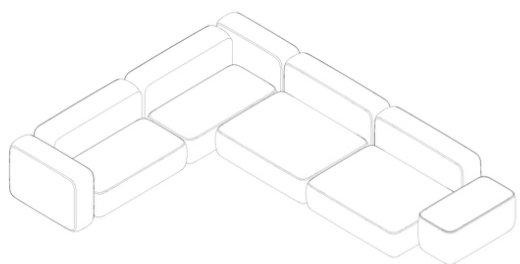

L_shape - 4

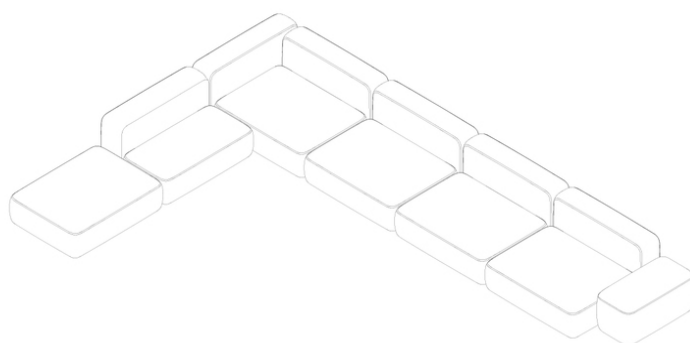

L_shape - 5

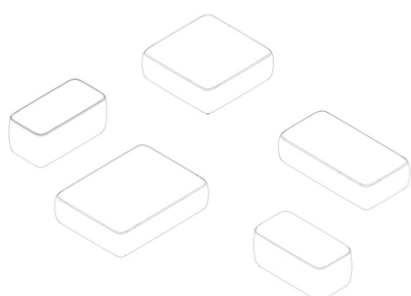

Pouf

PLUS

Francesco Rota | 2017

Modular seating in fire-retardant injected foam with removable fabric. Seats, backrests and armrest, also with hpl or wooden top, can be linked with brackets. PLUS can be matched with SCREEN partitions and OORT cushions.

TEST EN 1728:2012 AC:2013 6.17 - EN 16139:2013 - L2 extreme

TEST 1 IM - Hallingdal, Maya, Tonica

seats



94
37"

94
37"

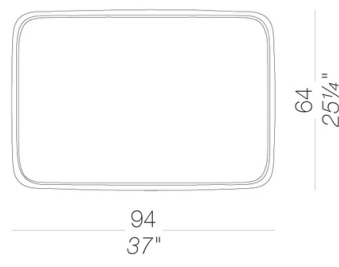
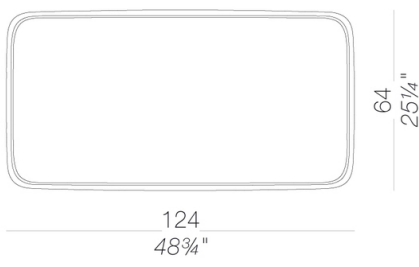
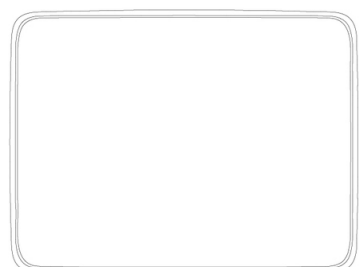

124
48 3/4"

124
48 3/4"

94
37"

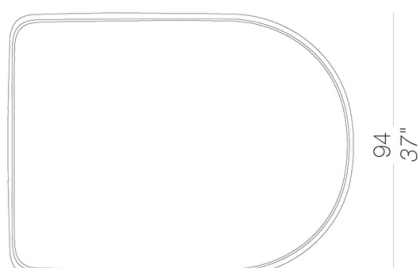

164
64 1/2"

118
46 1/2"

PLUS

Francesco Rota | 2017

backrests

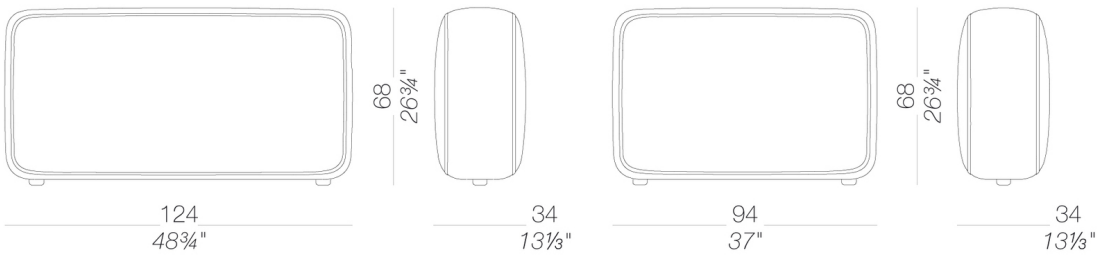

loose backrest

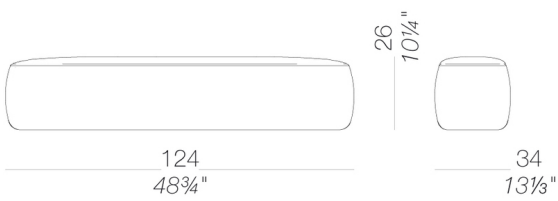

armrest

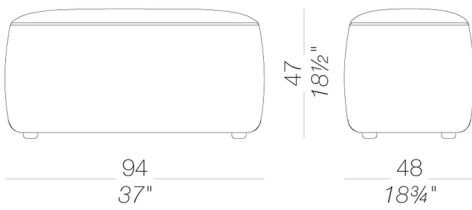

small table

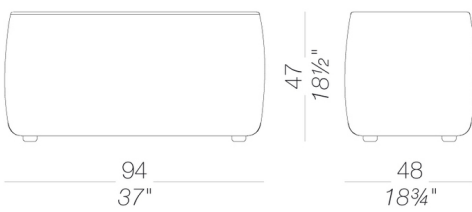

PLUS

Francesco Rota | 2017

upholstery



fabric
Hallingdal 65 -
Grade C
58 Colors



fabric
Canvas 2 - Grade C
45 Colors



fabric
Steelcut Trio 3 -
Grade D
54 Colors



fabric
Remix 3 - Grade C
72 Colors



fabric
Clara 2 - Grade C
24 Colors



fabric
Divina MD - Grade
D
27 Colors



fabric
Divina Melange 3 -
Grade D
38 Colors



fabric
Medley - Grade A
37 Colors

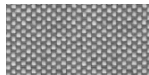

fabric
Maya - Grade A
43 Colors



fabric
Jet - Grade A
66 Colors



fabric
Fiorid 2 - Grade C
39 Colors



fabric
Tonica 2 - Grade C
39 Colors

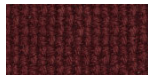

fabric
Lapalma Smart -
Grade C
18 Colors

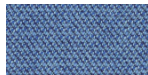

fabric
Capture - Grade B
43 Colors



fabric
Crisp - Grade B
40 Colors

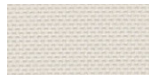

fabric
Nattè - Grade B
30 Colors



fabric
Iris - Grade B
24 Colors



fabric
Steelcut 3 - Grade
D
40 Colors

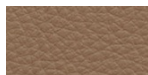

soft-leather
Soft-leather
17 Colors



ecoleather
GRIMM FR - Grade
A
32 Colors

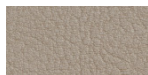

ecoleather
Valencia - Grade B
66 Colors



HPL 10 mm
HPL fenix
2 Colors



HPL 10 mm
HPL fenix
2 Colors



fabric
Grain - Grade. B
50 Colors



fabric
Re-wool - Grade C
21 Colors

top



HPL 10 mm
HPL fenix
2 Colors



HPL 10 mm
HPL fenix
2 Colors

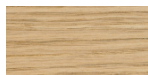

wood
blanch oak
1 Colors

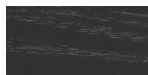

wood
black open pore
1 Colors

linking bracket



metal
aluminium
1 Colors

consult the portfolio for the range of colors, fabrics, eco-leather, soft-leather.

use and maintenance instructions

Clean all parts in wood, leather, fabric and metal with a damp cloth or a diluted neutral cleaner. Do not use cleaners with alcohol, bleach, solvent or abrasive products. Any liquid spilt on the product must be wiped up immediately. When lifting or moving the product, hold it on the structure and not under the seat. The product should not be subjected to unbalanced weights, as it is designed for a proper rest on the foothold (on four legs or on the base). Our company relieves from any responsibility in case of damage caused to fragile floors. Avoid any improper use of the product: do not step on the product, on the footrest or on the armrests. Avoid any movements that could compromise the proper functionality of the product or the safety of the users. Wood and leather, being natural materials, could be easily damaged. Small impurities or imperfections are within quality standard range. Do not expose the product to weather conditions or atmospheric agents, nor to heat sources over 40°C. Also products for outdoor use could be afflicted by atmospheric agents. The product could undergo possible exterior changes due to particular exposure to heat, humidity and saltiness. An appropriate and frequent maintenance and cleaning of the product enhances its durability. The product could change colour and shade, if exposed to direct sunlight. Maintenance has to be carried out by experienced staff. Dispose of the package only after assembling the product, in order to avoid the loss of ironmongery and components. Once the product has been dismantled, the product itself or its components must be given to the public garbage disposal system, according to the legislation in force.



Francesco Rota | 2017

Pouf, sofa, relaxation island: around a blue swimming pool or a green garden, the PLUS sofa invites us to pleasant outdoor moments. An idea is an addition. PLUS. An addition because this system of modular elements offers unparalleled elegance and versatility. An addition because the soft and attractive profile of each solution, from the pouf to the chair and sofa, extends to accommodate a body in the lying position. An addition because thanks to an extremely simple hooking system it just takes a second to re-arrange and redesign the profile. More than an idea, it is a world.



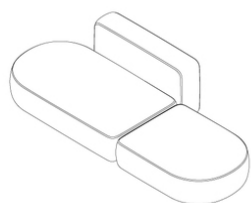

Classic curved

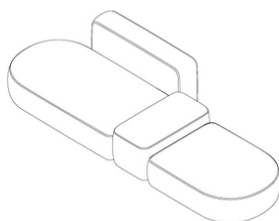

Classic curved — medium

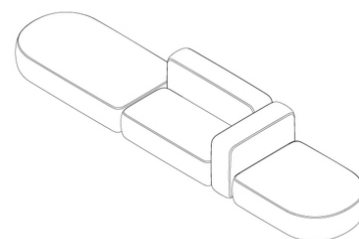

Classic curved — big

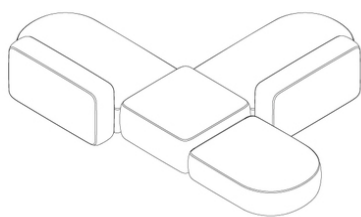

T_shape

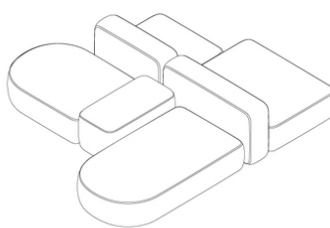

Island - 1

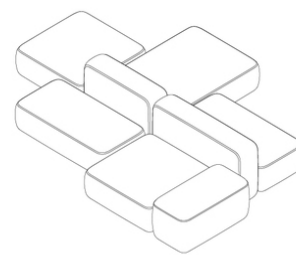

Island - 2

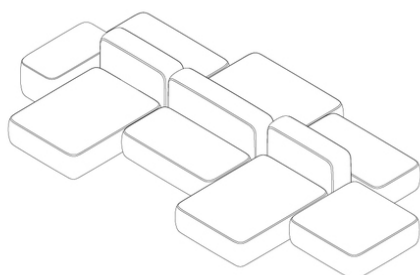

Island - 3

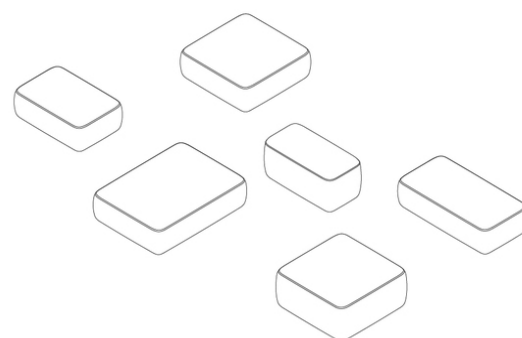

Pouf

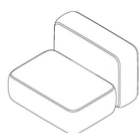

Armchair - 1

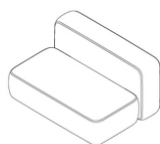

Armchair - 2

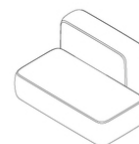

Armchair - 3

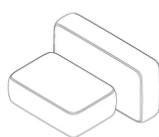

Armchair - 4

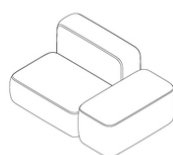

Armchair - 5

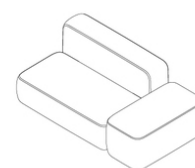

Armchair - 6

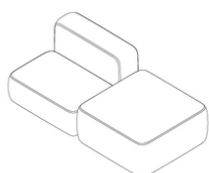

Armchair - 7

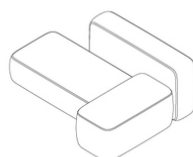

Armchair - 8

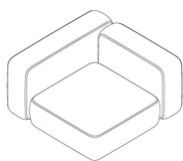

Chaise longue - 1

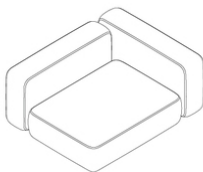

Chaise longue - 2

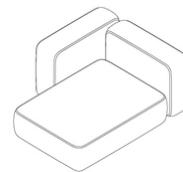

Chaise longue - 3

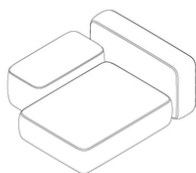

Chaise longue - 4

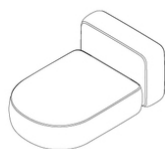

Chaise longue - 5

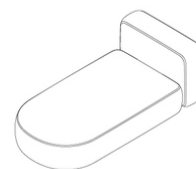

Chaise longue - 6

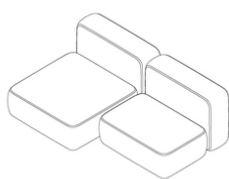

Small chaise longue - 1

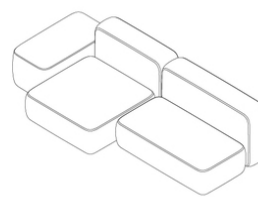

Small chaise longue - 2

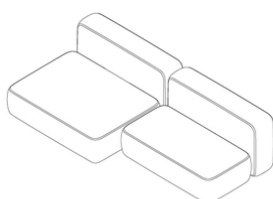

Large chaise longue - 1

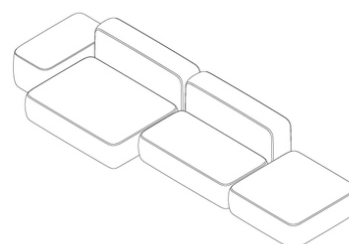

Large chaise longue - 2

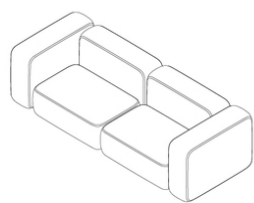

Small — double

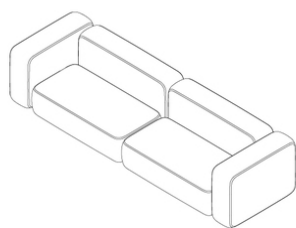

Large — double

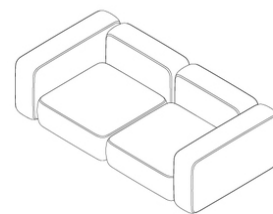

Small — deep

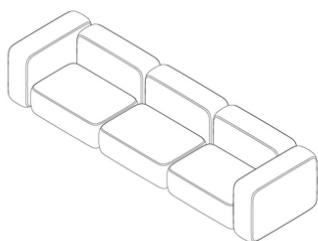

Small — triple

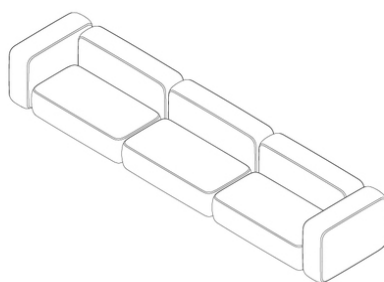

Large — triple

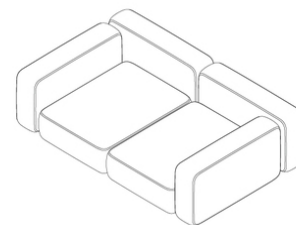

Large — deep

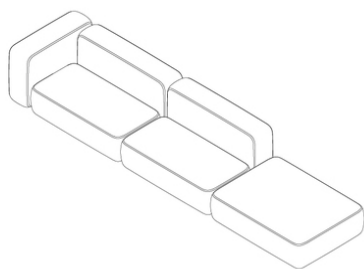

Large — open - 1

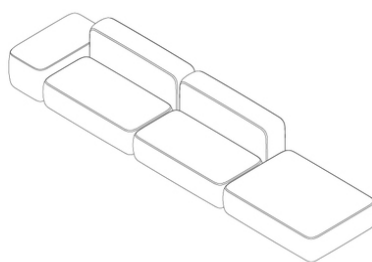

Large — open - 2

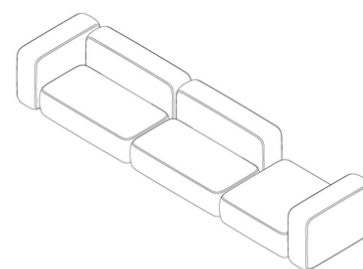

Large — open - 3

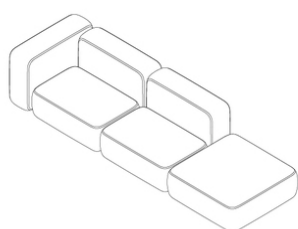

Small — open - 1

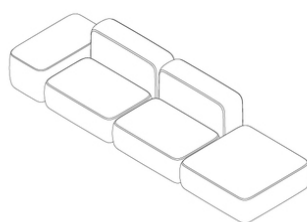

Small — open - 2

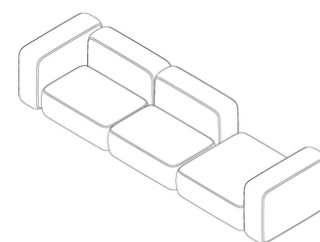

Small — open - 3

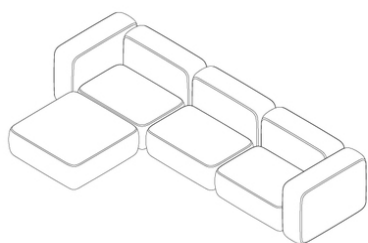

L_shape - 1

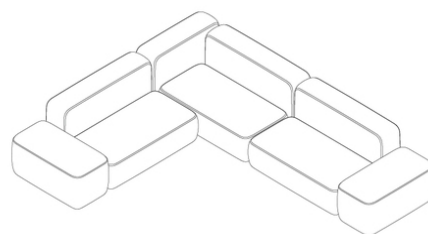

L_shape - 2

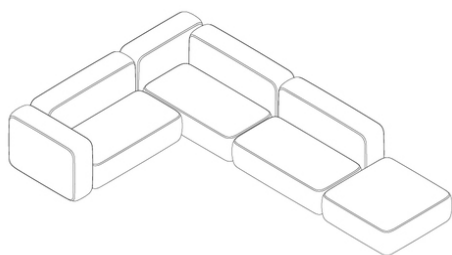

L_shape - 3

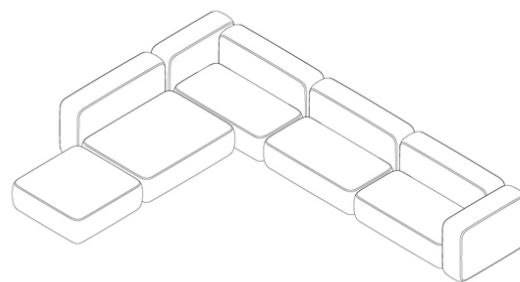

L_shape - 4

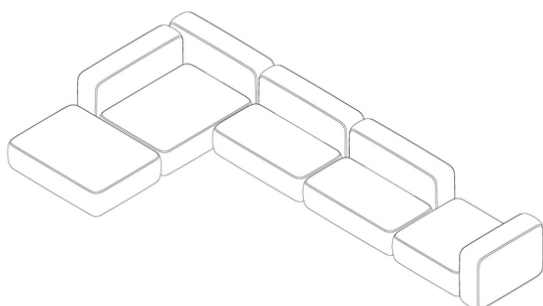

L_shape - 5

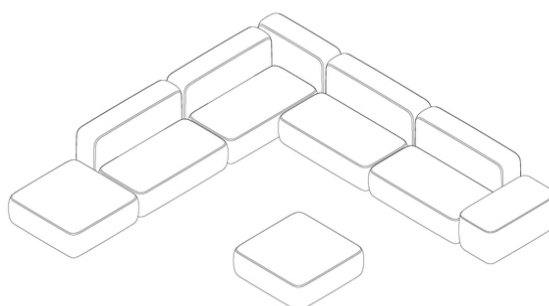

L_shape - 6

Modular seating system in polyurethane foam with variation in density and polyester fiber, all fire-retardant, with protective water-resistant and breathable fabric layer and finished with UV stable outdoor fabric. Internal base in marine plywood with plastic springs and an aluminium frame using diecast aluminium brackets to link each element. Water-resistant protective covers are available. PLUS can be matched with OORT cushions.

TEST EN 1728:2012 AC:2013 6.17 - EN 16139:2013 - L2 extreme

TEST EN 1728:2012 AC:2013 6.17 - EN 16139:2013 - L2 extreme

TEST 1 IM - Hallingdal, Maya, Tonica

seats

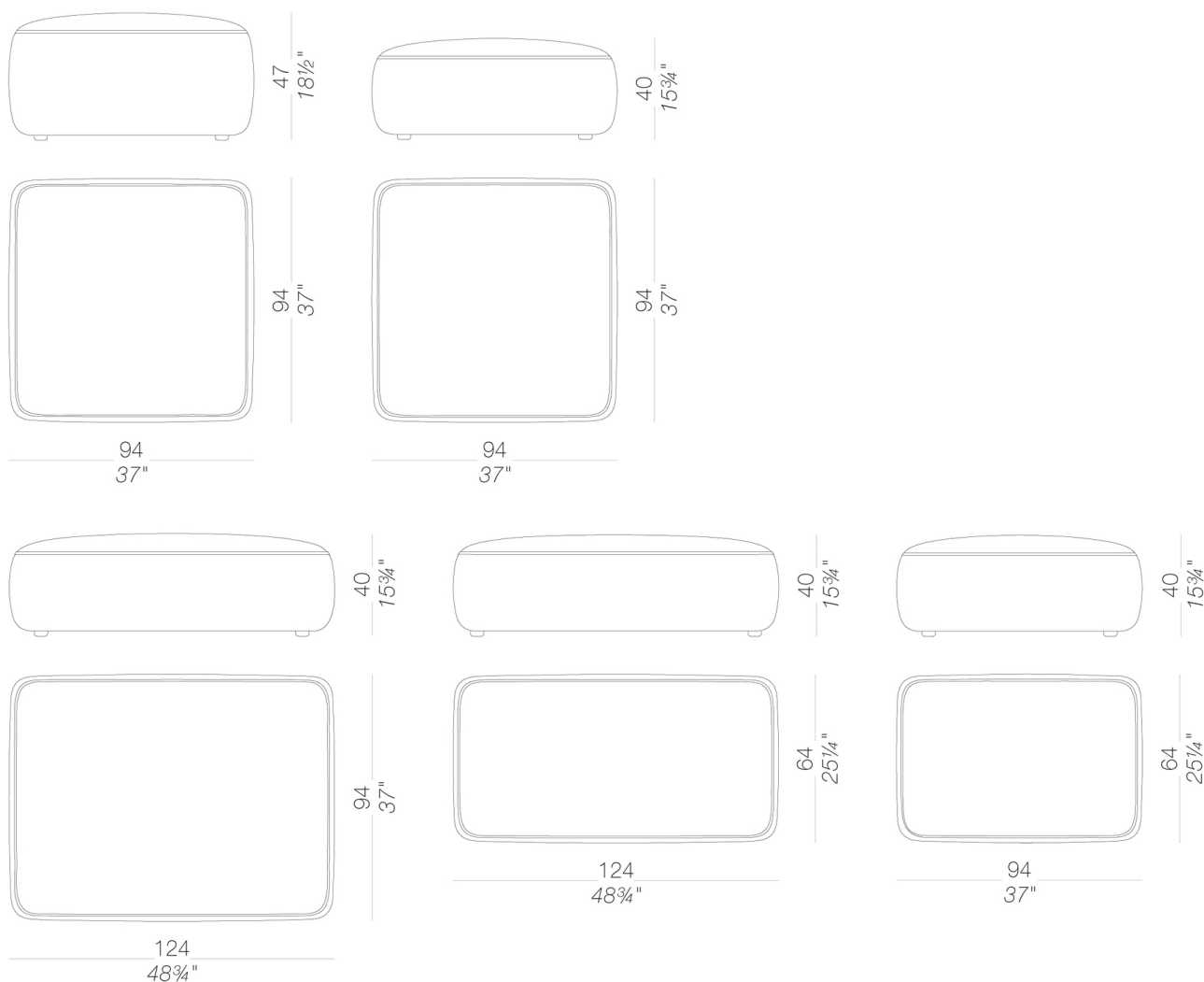

PLUS

Francesco Rota | 2017

seats

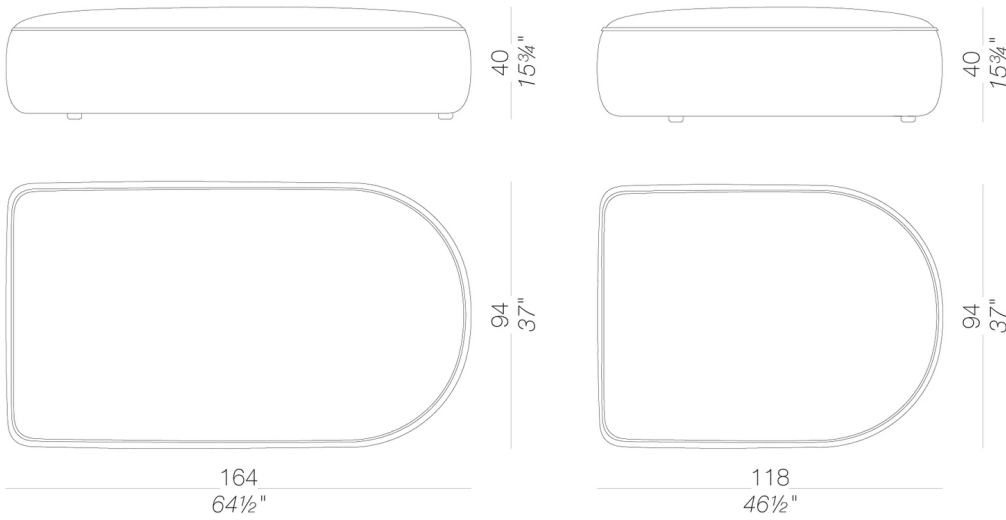

backrests

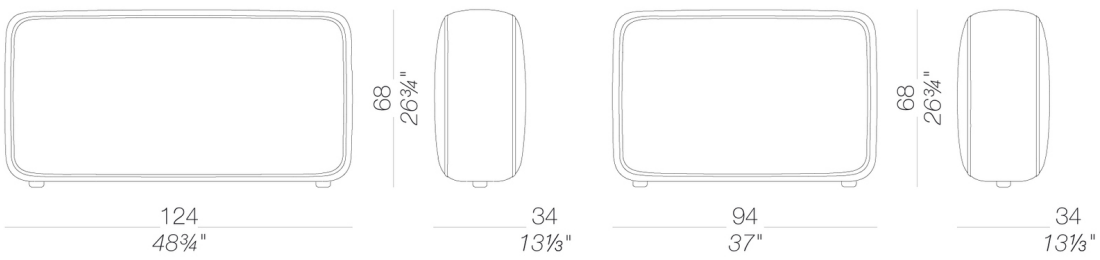

armrest

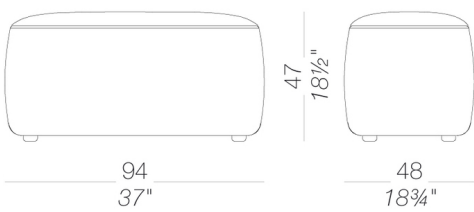

upholstery

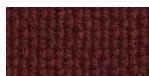

fabric
Lapalma Smart -
Grade C
18 Colors



fabric
Nattè - Grade B
30 Colors



fabric
Iliris - Grade B
24 Colors

linking bracket



metal
aluminium
1 Colors

consult the folder of materials for the range of colors and fabrics

use and maintenance instructions

Outdoor fabrics are lined unglued, therefore any creasing in the upholstery is an inevitable consequence of use and cannot be considered grounds for any claims. Do not use detergents containing bleach, hydrochloric acid or products containing chloride on any metal parts. Salt, limescale or acid (from coffee, wine, orange juice, tomato juice, lemon, etc.) may discolour stainless steel parts if they are not promptly cleaned. Products or parts made of stainless steel used near the sea or in interior fittings of swimming pools require more frequent cleaning to remove chloride deposits and prevent corrosion and chemical attack of the external surface. Stains on stainless steel surfaces must be promptly cleaned. If left for a long time they can become permanent.

To prolong the life of the product, clean the surfaces regularly, dry them with a clean cloth and remove any stagnant water, especially if exposed in locations with a high level of humidity or a marine climate. When not in use, we recommend storing in sheltered places and covering with waterproof protection. In this case, it is advisable to remove the cover and ventilate the product frequently and regularly to avoid the onset of any mould or stains due to damp.

THE WARRANTY WILL NOT COVER DEFECTS OR IMPERFECTIONS RESULTING FROM THE PASSAGE OF TIME OR TO WEAR AND TEAR DUE TO THE NORMAL USE OF THE PRODUCT.