

TUILE

Info

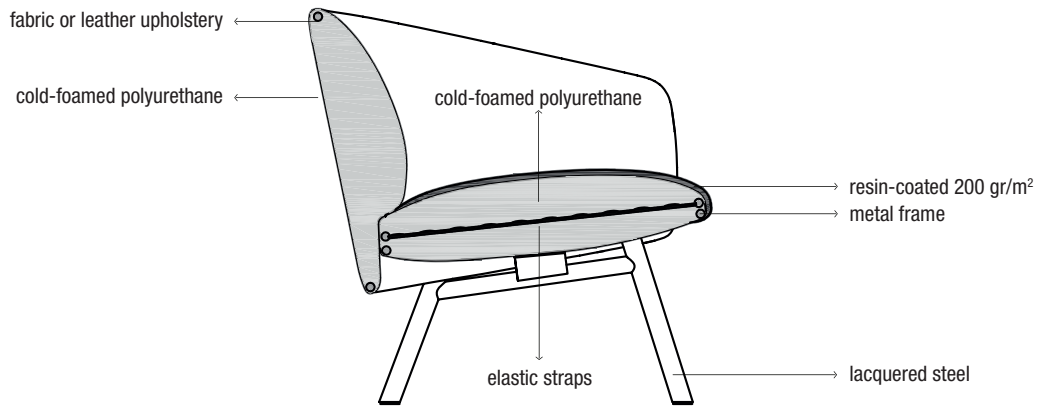

Legend:

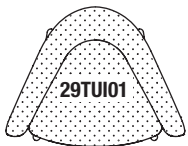

TUILE

3 seater sofa

Base finish:

White lacquered steel (colour reference "White polyurethane P001")
 Black lacquered steel (colour reference "Black polyurethane P003")
 Terracotta lacquered steel (colour reference "Terracotta polyurethane P006")
 Olive green lacquered steel (colour reference "Olive green polyurethane P008")
 London grey lacquered steel (colour reference "London grey 0718 Fenix-NTM®")

Finish of cover:

A = Valencia (synthetic leather)
 B = Field 2, COM (Customer fabric)
 C = Merit, COL (Customer leather)
 D = Clara 2, Patio, Regal, Remix 2
 E = Curmi, Hero, Melange Nap
 F = Canvas 2, Scuba, Steelcut trio 3
 G = Divina Melange 3, Hallingdal 65
 H = Twill Weave
 L1 = Coast (corrected grain leather)
 L2 = Elmosoft (semi-aniline leather)
 L3 = Elmotique (aniline leather)

Note:

REMOVABLE COVERS:
 Removable upholstery (*): FIELD 2, COM, CLARA 2, MERIT, CURMI, PATIO, REMIX 2, CANVAS 2, HERO, MELANGE NAP, STEELCUT TRIO 3, DIVINA MELANGE 3, HALLINGDAL 65, REGAL, TWILL WEAVE.
 Fixed upholstery: VALENCIA, COL, SCUBA, COAST, ELMOSOFT, ELMOTIQUE.
 (*) The upholstery is TECHNICALLY REMOVABLE but in order to ensure correct adhesion, it must be replaced exclusively by personnel specialised in upholstery.

For info on fabric composition, see inside cover.

For COM/COL orders, see inside cover.

COM consumption: 4,8 ml (H. 140 cm).
 COL consumption: 9,1 mq.

Reinforced packaging, see inside cover.

Code	Base	Cover											pack	m ³	Kg			
		A	B	C	D	E	F	G	H	L1	L2	L3						
29TUI03	Lacquered steel															1	1,75	85

Optionals

Code	Description	pack	m ³	Kg
29TUI03	Fire-retardant	-	-	-
	Cushions, see page 121	-	-	-

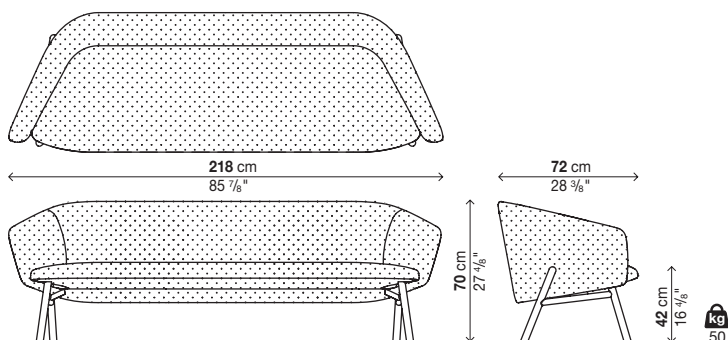

TUILE

2 seater sofa

Base finish:

White lacquered steel (colour reference "White polyurethane P001")
 Black lacquered steel (colour reference "Black polyurethane P003")
 Terracotta lacquered steel (colour reference "Terracotta polyurethane P006")
 Olive green lacquered steel (colour reference "Olive green polyurethane P008")
 London grey lacquered steel (colour reference "London grey 0718 Fenix-NTM®")

Finish of cover:

A = Valencia (synthetic leather)
 B = Field 2, COM (Customer fabric)
 C = Merit, COL (Customer leather)
 D = Clara 2, Patio, Regal, Remix 2
 E = Curmi, Hero, Melange Nap
 F = Canvas 2, Scuba, Steelcut trio 3
 G = Divina Melange 3, Hallingdal 65
 H = Twill Weave
 L1 = Coast (corrected grain leather)
 L2 = Elmosoft (semi-aniline leather)
 L3 = Elmotique (aniline leather)

Note:

REMOVABLE COVERS:
 Removable upholstery (*): FIELD 2, COM, CLARA 2, MERIT, CURMI, PATIO, REMIX 2, CANVAS 2, HERO, MELANGE NAP, STEELCUT TRIO 3, DIVINA MELANGE 3, HALLINGDAL 65, REGAL, TWILL WEAVE.
 Fixed upholstery: VALENCIA, COL, SCUBA, COAST, ELMOSOFT, ELMOTIQUE.
 (*) The upholstery is TECHNICALLY REMOVABLE but in order to ensure correct adhesion, it must be replaced exclusively by personnel specialised in upholstery.

For info on fabric composition, see inside cover.

For COM/COL orders, see inside cover.

COM consumption: 3,6 ml (H. 140 cm).
 COL consumption: 6,8 mq.

Reinforced packaging, see inside cover.

Code	Base	Cover											pack	m ³	Kg		
		A	B	C	D	E	F	G	H	L1	L2	L3					
29TUI02	Lacquered steel														1	1,3	78

Optionals

Code	Description	pack	m ³	Kg
29TUI02	Fire-retardant	-	-	-
	Cushions, see page 121	-	-	-

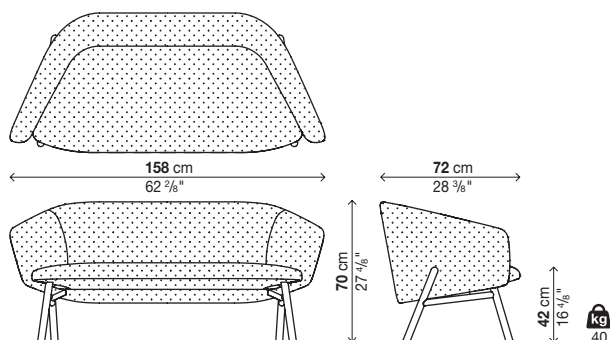

TUILE

Armchair

Base finish:

White lacquered steel (colour reference "White polyurethane P001")
 Black lacquered steel (colour reference "Black polyurethane P003")
 Terracotta lacquered steel (colour reference "Terracotta polyurethane P006")
 Olive green lacquered steel (colour reference "Olive green polyurethane P008")
 London grey lacquered steel (colour reference "London grey 0718 Fenix-NTM®")

Finish of cover:

A = Valencia (synthetic leather)
 B = Field 2, COM (Customer fabric)
 C = Merit, COL (Customer leather)
 D = Clara 2, Patio, Regal, Remix 2
 E = Curmi, Hero, Melange Nap
 F = Canvas 2, Scuba, Steelcut trio 3
 G = Divina Melange 3, Hallingdal 65
 H = Twill Weave
 L1 = Coast (corrected grain leather)
 L2 = Elmosoft (semi-aniline leather)
 L3 = Elmotique (aniline leather)

Note:

REMOVABLE COVERS:
 Removable upholstery (*): FIELD 2, COM, CLARA 2, MERIT, CURMI, PATIO, REMIX 2, CANVAS 2, HERO, MELANGE NAP, STEELCUT TRIO 3, DIVINA MELANGE 3, HALLINGDAL 65, REGAL, TWILL WEAVE.
 Fixed upholstery: VALENCIA, COL, SCUBA, COAST, ELMOSOFT, ELMOTIQUE.
 (*) The upholstery is TECHNICALLY REMOVABLE but in order to ensure correct adhesion, it must be replaced exclusively by personnel specialised in upholstery.

For info on fabric composition, see inside cover.

For COM/COL orders, see inside cover.

COM consumption: 2,2 ml (H. 140 cm).
 COL consumption: 4,2 mq.

Reinforced packaging, see inside cover.

Code	Base	Cover											pack	m ³	Kg			
		A	B	C	D	E	F	G	H	L1	L2	L3						
29TUI01	Lacquered steel															1	0,75	40

Optionals

Code	Description	pack	m ³	Kg
29TUI01	Fire-retardant	-	-	-
	Cushions, see page 121	-	-	-

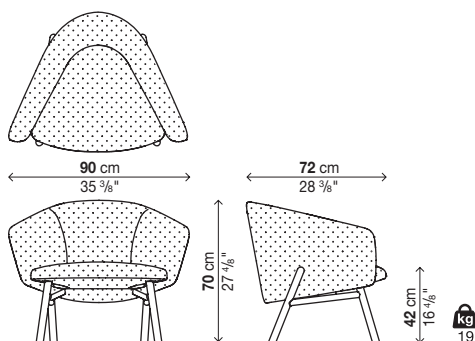

TUILE SYSTEM

Info

Legend:

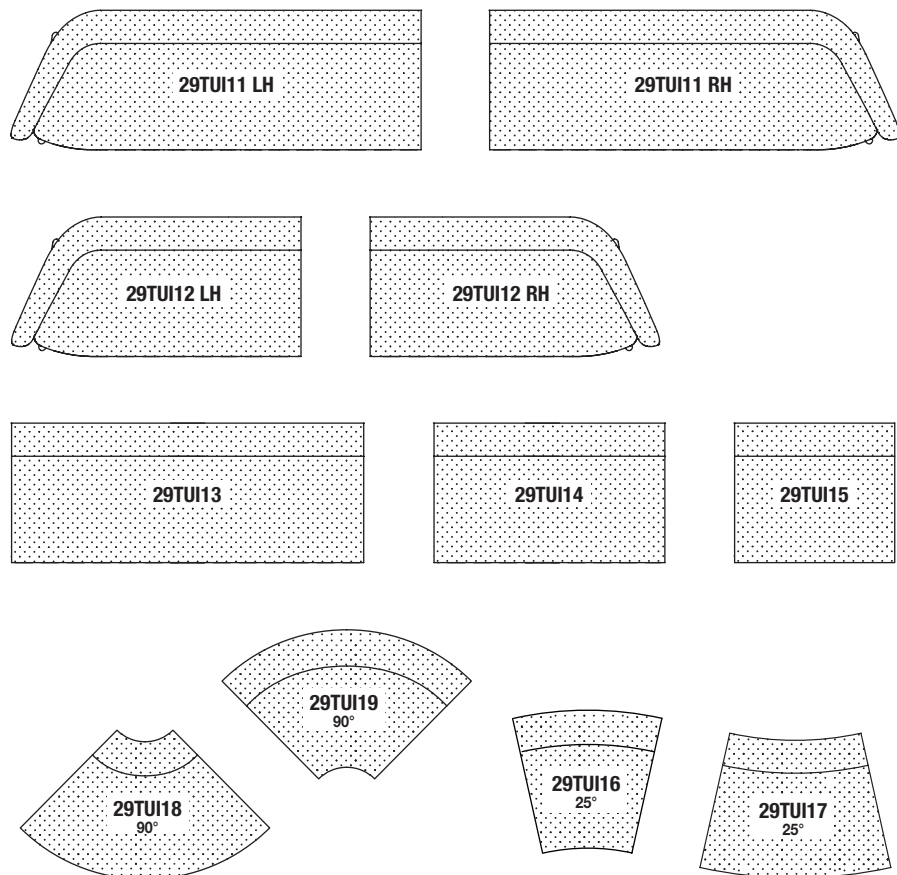

Attention:

Add the sketch of the arrangement with the list of each single element to the order.

TUILE SYSTEM

Examples of composition

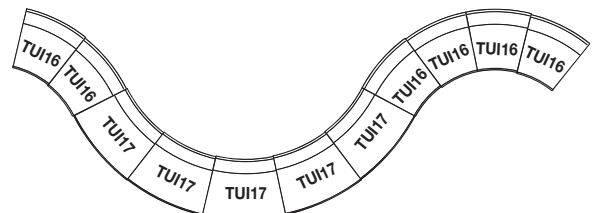
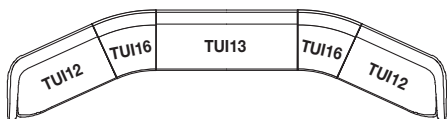
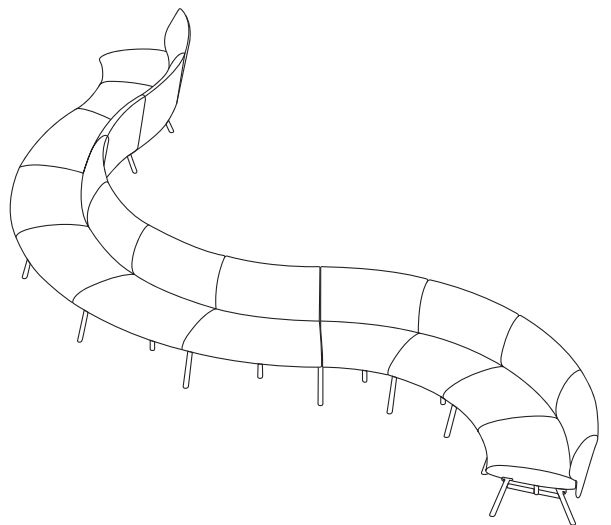
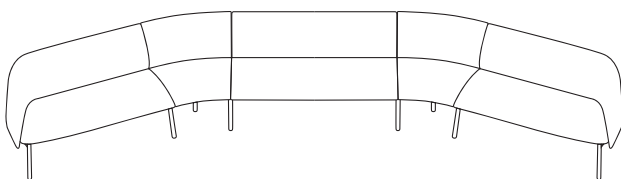
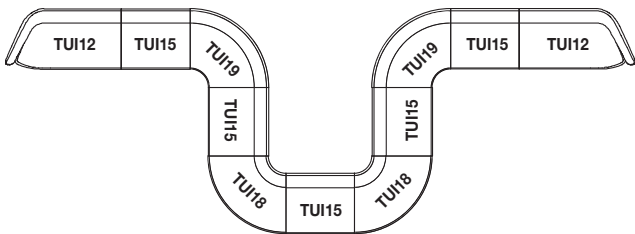
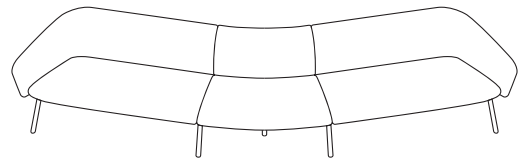
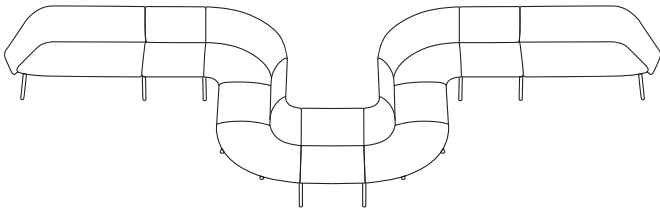
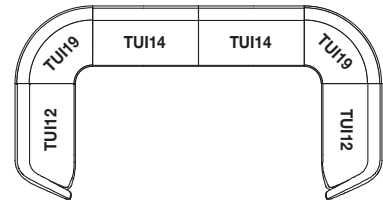
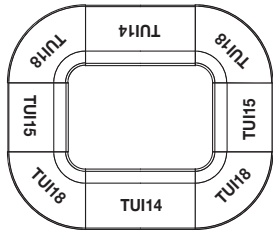
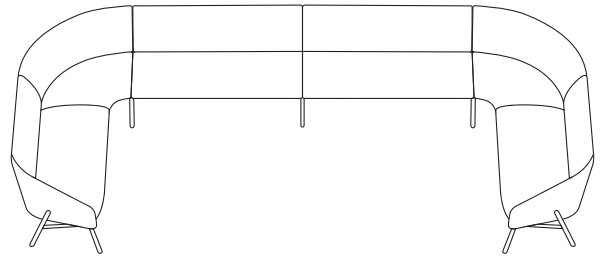
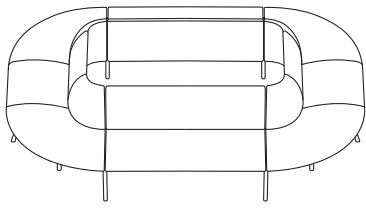

TUILE SYSTEM

Terminal module 3 seat rh/lh

Base finish:

White lacquered steel (colour reference "White polyurethane P001")
 Black lacquered steel (colour reference "Black polyurethane P003")
 Terracotta lacquered steel (colour reference "Terracotta polyurethane P006")
 Olive green lacquered steel (colour reference "Olive green polyurethane P008")
 London grey lacquered steel (colour reference "London grey 0718 Fenix-NTM®")

Finish of cover:

A = Valencia (synthetic leather)
 B = Field 2, COM (Customer fabric)
 C = Merit, COL (Customer leather)
 D = Clara 2, Patio, Regal, Remix 2
 E = Curmi, Hero, Melange Nap
 F = Canvas 2, Scuba, Steelcut trio 3
 G = Divina Melange 3, Hallingdal 65
 H = Twill Weave
 L1 = Coast (corrected grain leather)
 L2 = Elmosoft (semi-aniline leather)
 L3 = Elmotique (aniline leather)

Note:

REMOVABLE COVERS:
 Removable upholstery (*): FIELD 2, COM, CLARA 2, MERIT, CURMI, PATIO, REMIX 2, CANVAS 2, HERO, MELANGE NAP, STEELCUT TRIO 3, DIVINA MELANGE 3, HALLINGDAL 65, REGAL, TWILL WEAVE.
 Fixed upholstery: VALENCIA, COL, SCUBA, COAST, ELMOSOFT, ELMOTIQUE.
 (*) The upholstery is TECHNICALLY REMOVABLE but in order to ensure correct adhesion, it must be replaced exclusively by personnel specialised in upholstery.

For info on fabric composition, see inside cover.

For COM/COL orders, see inside cover.

COM consumption: 4,9 ml (H. 140 cm).
 COL consumption: 9,8 mq.

Reinforced packaging, see inside cover.

Code	Base	Cover											pack	m ³	Kg		
		A	B	C	D	E	F	G	H	L1	L2	L3					
29TUI11	Lacquered steel																

Optionals

Code	Description	pack	m ³	Kg
29TUI11	Fire-retardant	-	-	-
	Cushions, see page 121	-	-	-

20TUI11 SX/LH

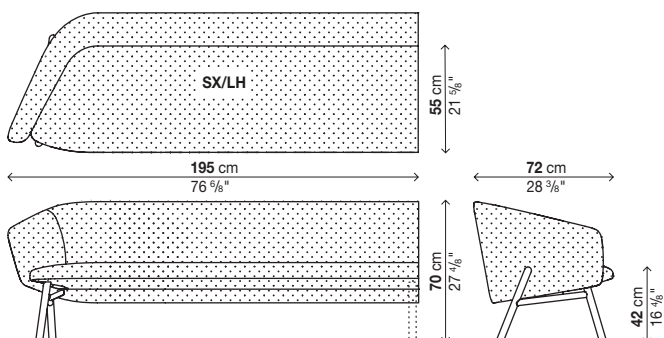

20TUI11 DX/RH

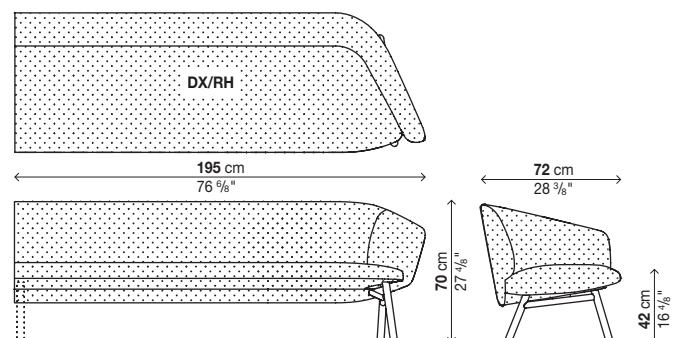

TUILE SYSTEM

Terminal module 2 seat rh/lh

Base finish:

White lacquered steel (colour reference "White polyurethane P001")
 Black lacquered steel (colour reference "Black polyurethane P003")
 Terracotta lacquered steel (colour reference "Terracotta polyurethane P006")
 Olive green lacquered steel (colour reference "Olive green polyurethane P008")
 London grey lacquered steel (colour reference "London grey 0718 Fenix-NTM®")

Finish of cover:

A = Valencia (synthetic leather)
 B = Field 2, COM (Customer fabric)
 C = Merit, COL (Customer leather)
 D = Clara 2, Patio, Regal, Remix 2
 E = Curmi, Hero, Melange Nap
 F = Canvas 2, Scuba, Steelcut trio 3
 G = Divina Melange 3, Hallingdal 65
 H = Twill Weave
 L1 = Coast (corrected grain leather)
 L2 = Elmosoft (semi-aniline leather)
 L3 = Elmotique (aniline leather)

Note:

REMOVABLE COVERS:
 Removable upholstery (*): FIELD 2, COM, CLARA 2, MERIT, CURMI, PATIO, REMIX 2, CANVAS 2, HERO, MELANGE NAP, STEELCUT TRIO 3, DIVINA MELANGE 3, HALLINGDAL 65, REGAL, TWILL WEAVE.
 Fixed upholstery: VALENCIA, COL, SCUBA, COAST, ELMOSOFT, ELMOTIQUE.
 (*) The upholstery is TECHNICALLY REMOVABLE but in order to ensure correct adhesion, it must be replaced exclusively by personnel specialised in upholstery.

For info on fabric composition, see inside cover.

For COM/COL orders, see inside cover.

COM consumption: 3,7 ml (H. 140 cm).
 COL consumption: 7,4 mq.

Reinforced packaging, see inside cover.

Code	Base	Cover											pack	m ³	Kg		
		A	B	C	D	E	F	G	H	L1	L2	L3					
29TUI12	Lacquered steel																

Optionals

Code	Description	pack	m ³	Kg
29TUI12	Fire-retardant	-	-	-
	Cushions, see page 121	-	-	-

20TUI12 SX/LH

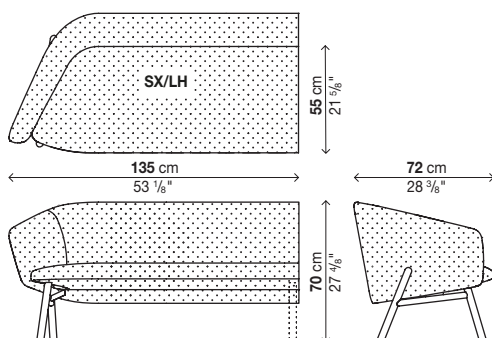

20TUI12 DX/RH

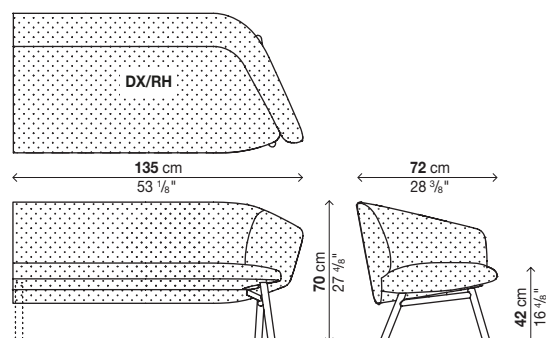

TUILE SYSTEM

Intermediate module 3 seats

Base finish:

White lacquered steel (colour reference "White polyurethane P001")
 Black lacquered steel (colour reference "Black polyurethane P003")
 Terracotta lacquered steel (colour reference "Terracotta polyurethane P006")
 Olive green lacquered steel (colour reference "Olive green polyurethane P008")
 London grey lacquered steel (colour reference "London grey 0718 Fenix-NTM®")

Finish of cover:

A = Valencia (synthetic leather)
 B = Field 2, COM (Customer fabric)
 C = Merit, COL (Customer leather)
 D = Clara 2, Patio, Regal, Remix 2
 E = Curmi, Hero, Melange Nap
 F = Canvas 2, Scuba, Steelcut trio 3
 G = Divina Melange 3, Hallingdal 65
 H = Twill Weave
 L1 = Coast (corrected grain leather)
 L2 = Elmosoft (semi-aniline leather)
 L3 = Elmotique (aniline leather)

Note:

REMOVABLE COVERS:
 Removable upholstery (*): FIELD 2, COM, CLARA 2, MERIT, CURMI, PATIO, REMIX 2, CANVAS 2, HERO, MELANGE NAP, STEELCUT TRIO 3, DIVINA MELANGE 3, HALLINGDAL 65, REGAL, TWILL WEAVE.
 Fixed upholstery: VALENCIA, COL, SCUBA, COAST, ELMOSOFT, ELMOTIQUE.
 (*) The upholstery is TECHNICALLY REMOVABLE but in order to ensure correct adhesion, it must be replaced exclusively by personnel specialised in upholstery.

For info on fabric composition, see inside cover.

For COM/COL orders, see inside cover.

COM consumption: 4,2 ml (H. 140 cm).
 COL consumption: 8,4 mq.

Reinforced packaging, see inside cover.

Code	Base	Cover											pack	m ³	Kg		
		A	B	C	D	E	F	G	H	L1	L2	L3					
29TUI13	Lacquered steel																

Optionals

Code	Description	pack	m ³	Kg
29TUI13	Fire-retardant	-	-	-
	Cushions, see page 121	-	-	-

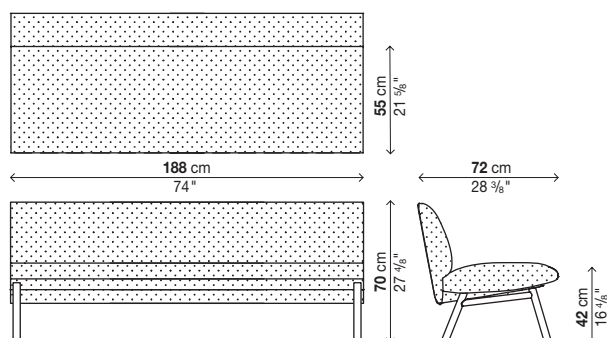

TUILE SYSTEM

Intermediate module 2 seats

Base finish:

White lacquered steel (colour reference "White polyurethane P001")
 Black lacquered steel (colour reference "Black polyurethane P003")
 Terracotta lacquered steel (colour reference "Terracotta polyurethane P006")
 Olive green lacquered steel (colour reference "Olive green polyurethane P008")
 London grey lacquered steel (colour reference "London grey 0718 Fenix-NTM®")

Finish of cover:

A = Valencia (synthetic leather)
 B = Field 2, COM (Customer fabric)
 C = Merit, COL (Customer leather)
 D = Clara 2, Patio, Regal, Remix 2
 E = Curmi, Hero, Melange Nap
 F = Canvas 2, Scuba, Steelcut trio 3
 G = Divina Melange 3, Hallingdal 65
 H = Twill Weave
 L1 = Coast (corrected grain leather)
 L2 = Elmosoft (semi-aniline leather)
 L3 = Elmotique (aniline leather)

Note:

REMOVABLE COVERS:
 Removable upholstery (*): FIELD 2, COM, CLARA 2, MERIT, CURMI, PATIO, REMIX 2, CANVAS 2, HERO, MELANGE NAP, STEELCUT TRIO 3, DIVINA MELANGE 3, HALLINGDAL 65, REGAL, TWILL WEAVE.
 Fixed upholstery: VALENCIA, COL, SCUBA, COAST, ELMOSOFT, ELMOTIQUE.
 (*) The upholstery is TECHNICALLY REMOVABLE but in order to ensure correct adhesion, it must be replaced exclusively by personnel specialised in upholstery.

For info on fabric composition, see inside cover.

For COM/COL orders, see inside cover.

COM consumption: 3,1 ml (H. 140 cm).
 COL consumption: 6,2 mq.

Reinforced packaging, see inside cover.

Code	Base	Cover											pack	m ³	Kg		
		A	B	C	D	E	F	G	H	L1	L2	L3					
29TUI14	Lacquered steel																

Optionals

Code	Description	pack	m ³	Kg
29TUI14	Fire-retardant	-	-	-
	Cushions, see page 121	-	-	-

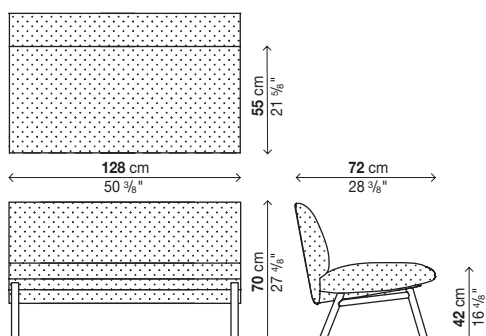

TUILE SYSTEM

Intermediate module 1 seat

Base finish:

White lacquered steel (colour reference "White polyurethane P001")
 Black lacquered steel (colour reference "Black polyurethane P003")
 Terracotta lacquered steel (colour reference "Terracotta polyurethane P006")
 Olive green lacquered steel (colour reference "Olive green polyurethane P008")
 London grey lacquered steel (colour reference "London grey 0718 Fenix-NTM®")

Finish of cover:

A = Valencia (synthetic leather)
 B = Field 2, COM (Customer fabric)
 C = Merit, COL (Customer leather)
 D = Clara 2, Patio, Regal, Remix 2
 E = Curmi, Hero, Melange Nap
 F = Canvas 2, Scuba, Steelcut trio 3
 G = Divina Melange 3, Hallingdal 65
 H = Twill Weave
 L1 = Coast (corrected grain leather)
 L2 = Elmosoft (semi-aniline leather)
 L3 = Elmotique (aniline leather)

Note:

REMOVABLE COVERS:
 Removable upholstery (*): FIELD 2, COM, CLARA 2, MERIT, CURMI, PATIO, REMIX 2, CANVAS 2, HERO, MELANGE NAP, STEELCUT TRIO 3, DIVINA MELANGE 3, HALLINGDAL 65, REGAL, TWILL WEAVE.
 Fixed upholstery: VALENCIA, COL, SCUBA, COAST, ELMOSOFT, ELMOTIQUE.
 (*) The upholstery is TECHNICALLY REMOVABLE but in order to ensure correct adhesion, it must be replaced exclusively by personnel specialised in upholstery.

For info on fabric composition, see inside cover.

For COM/COL orders, see inside cover.

COM consumption: 2,1 ml (H. 140 cm).
 COL consumption: 4 mq.

Reinforced packaging, see inside cover.

Code	Base	Cover											pack	m ³	Kg		
		A	B	C	D	E	F	G	H	L1	L2	L3					
29TUI15	Lacquered steel																

Optionals

Code	Description	pack	m ³	Kg
29TUI15	Fire-retardant	-	-	-
	Cushions, see page 121	-	-	-

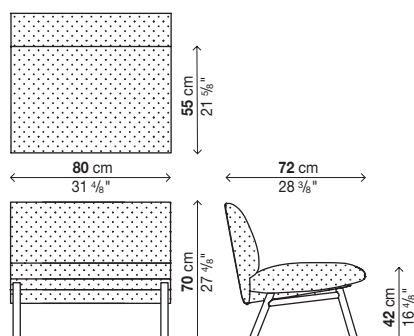

TUILE SYSTEM

Corner element 90°

Base finish:

White lacquered steel (colour reference "White polyurethane P001")
 Black lacquered steel (colour reference "Black polyurethane P003")
 Terracotta lacquered steel (colour reference "Terracotta polyurethane P006")
 Olive green lacquered steel (colour reference "Olive green polyurethane P008")
 London grey lacquered steel (colour reference "London grey 0718 Fenix-NTM®")

Finish of cover:

A = Valencia (synthetic leather)
 B = Field 2, COM (Customer fabric)
 C = Merit, COL (Customer leather)
 D = Clara 2, Patio, Regal, Remix 2
 E = Curmi, Hero, Melange Nap
 F = Canvas 2, Scuba, Steelcut trio 3
 G = Divina Melange 3, Hallingdal 65
 H = Twill Weave
 L1 = Coast (corrected grain leather)
 L2 = Elmosoft (semi-aniline leather)
 L3 = Elmotique (aniline leather)

Note:

REMOVABLE COVERS:
 Removable upholstery (*): FIELD 2, COM, CLARA 2, MERIT, CURMI, PATIO, REMIX 2, CANVAS 2, HERO, MELANGE NAP, STEELCUT TRIO 3, DIVINA MELANGE 3, HALLINGDAL 65, REGAL, TWILL WEAVE.
 Fixed upholstery: VALENCIA, COL, SCUBA, COAST, ELMOSOFT, ELMOTIQUE.
 (*) The upholstery is TECHNICALLY REMOVABLE but in order to ensure correct adhesion, it must be replaced exclusively by personnel specialised in upholstery.

For info on fabric composition, see inside cover.

For COM/COL orders, see inside cover.

Consumption corner element 90° open:
 COM consumption: 3,1 ml (H. 140 cm).
 COL consumption: 5,9 mq.
 Consumption corner element 90° close:
 COM consumption: 4 ml (H. 140 cm).
 COL consumption: 7,7 mq.

Reinforced packaging, see inside cover.

Code	Description	Base	Cover											pack	m ³	Kg	
			A	B	C	D	E	F	G	H	L1	L2	L3				
29TUI18	90° corner open	Lacquered steel															
29TUI19	90° corner close	Lacquered steel															

Optionals

Code	Description	pack	m ³	Kg
29TUI18	Fire-retardant	-	-	-
29TUI19	Fire-retardant	-	-	-
	Cushions, see page 121	-	-	-

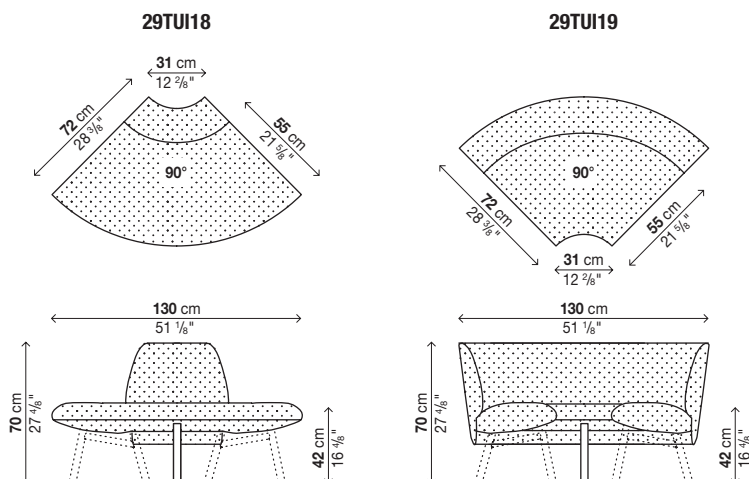

TUILE SYSTEM

Corner element 25°

Base finish:

- White lacquered steel (colour reference "White polyurethane P001")
- Black lacquered steel (colour reference "Black polyurethane P003")
- Terracotta lacquered steel (colour reference "Terracotta polyurethane P006")
- Olive green lacquered steel (colour reference "Olive green polyurethane P008")
- London grey lacquered steel (colour reference "London grey 0718 Fenix-NTM®")

Finish of cover:

- A = Valencia (synthetic leather)
- B = Field 2, COM (Customer fabric)
- C = Merit, COL (Customer leather)
- D = Clara 2, Patio, Regal, Remix 2
- E = Curmi, Hero, Melange Nap
- F = Canvas 2, Scuba, Steelcut trio 3
- G = Divina Melange 3, Hallingdal 65
- H = Twill Weave
- L1 = Coast (corrected grain leather)
- L2 = Elmosoft (semi-aniline leather)
- L3 = Elmotique (aniline leather)

Note:

REMOVABLE COVERS:
 Removable upholstery (*): FIELD 2, COM, CLARA 2, MERIT, CURMI, PATIO, REMIX 2, CANVAS 2, HERO, MELANGE NAP, STEELCUT TRIO 3, DIVINA MELANGE 3, HALLINGDAL 65, REGAL, TWILL WEAVE.
 Fixed upholstery: VALENCIA, COL, SCUBA, COAST, ELMOSOFT, ELMOTIQUE.
 (*) The upholstery is TECHNICALLY REMOVABLE but in order to ensure correct adhesion, it must be replaced exclusively by personnel specialised in upholstery.

For info on fabric composition, see inside cover.

For COM/COL orders, see inside cover.

Consumption corner element 25° open:
 COM consumption: 2,7 ml (H. 140 cm).
 COL consumption: 5,2 mq.
 Consumption corner element 25° close:
 COM consumption: 2 ml (H. 140 cm).
 COL consumption: 3,9 mq.

Reinforced packaging, see inside cover.

Code	Description	Base	Cover											pack	m ²	Kg	
			A	B	C	D	E	F	G	H	L1	L2	L3				
29TUI16	25° corner open	Lacquered steel															
29TUI17	25° corner close	Lacquered steel															

Optionals

Code	Description	pack	m ²	Kg
29TUI16	Fire-retardant	-	-	-
29TUI17	Fire-retardant	-	-	-
	Cushions, see page 121	-	-	-

